

# E024

## SUB MINIATURE SERVOVALVE

Low weight, small size, high performance for motorsport and other high performance applications



Motorsport presents a number of unique challenges to motion control suppliers, particularly Formula 1's requirements of low weight, small size and performance.

The E024 Series Miniature Servovalve was developed from the proven E030 series aerospace servovalve widely used for flight control in civil and military aircraft.

Compared to the E030, it is significantly reduced in size and weight, but retains a flow capability of up to 7.5 l/min (2 USg/min) to meet the requirements of the vast majority of motorsport applications. This valve retains the robust two-stage nozzle flapper construction for the 30/50 Series Valve, to meet the extreme performance and environmental demands of the motorsport industry.



### THREE BASIC VERSIONS OF THE E024 VALVE ARE AVAILABLE:

- 1 An axis cut version for use in position, pressure and force control applications.
- 2 A special gear box indexing version for open-loop control of ratchet mechanisms.
- 3 A dual gain Servovalve designed to significantly improve resolution and response in critical systems such as selector drum positioning, clutch control and throttle control.

### ADVANTAGES OF THE E024 VALVE

- Ultra light-weight 92gm (3.24 oz)
- Compact package
- High power density
- Low input signal (10mA)
- Compatible with F1 ecu
- Fast response to command inputs
- Excellent energy efficiency
- High peak flow capability
- Precise, repeatable characteristic control

### INDUSTRY APPLICATIONS

- Formula 1 (Throttle actuation, Differential control, Gearbox actuation, Power assisted steering, clutch control, Front wing actuation)
- Medical
- Subsea equipment
- Special effects in film and theatre

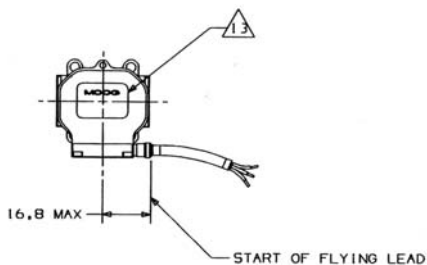
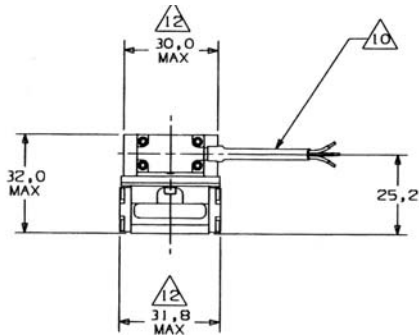
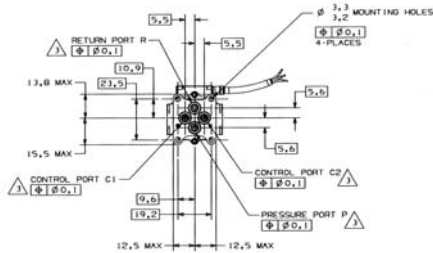
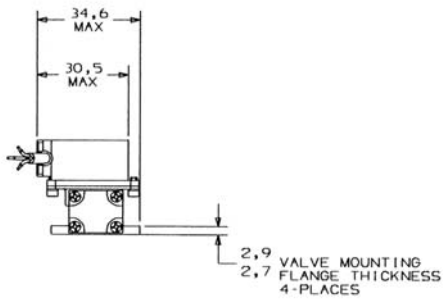

## TECHNICAL DATA E024 SUB MINIATURE SERVOVALVES

	E024	E024 Dual Flow Rate
<b>Maximum Supply Pressure:</b>	210 Bar (3045 PSi)	
<b>Valve Function:</b>	Axis-cut linear flow control.	Axis-cut flow control with dual gain [Ratio 2.5:1].
<b>Rated Flow: @ 70 Bar (1015 PSi) Valve Pressure Drop</b>	Axis-cut valves: 0.4, 1.0, 1.5, 2.0, 3.8, 5.0, 7.0, 7.4, 5.6 l/m. (0.1, 0.3, 0.4, 0.5, 1.0, 1.3, 1.8, 1.9, 1.5 USg/min). Gearbox indexing version; 7.4 l/min (1.9 USg/min) (engage) 5.6 l/min (1.5 USg/min) (re-set). NB Flow Tolerance +/-10%.	2.0, 3.8, 7.0 l/min (0.5, 1.0, 1.8 USg/min). NB: Flow tolerance +/-10%.
<b>Leakage Flow:</b>	Pilot stage flow: < 0.30 l/min (0.08 USg/min) (std version). Spool leakage at null: < 5% of rated flow (Axis-cut versions).	Pilot stage flow: < 0.30 l/min (0.08 USg/min). Spool leakage at null: < 2% of rated flow (Axis-cut versions).
<b>Electrical Input Signal: (coils in parallel)</b>	+/- 10mA into a 360 ohm. Inductance 1.4 Henry.	
<b>Dynamic Performance:</b>	<b>25% signal @ 210 Bar (3045 PSi) &amp; 40°C (104°F)</b> 90° phase lag > 250 Hz -3dB attenuation > 250 Hz.	<b>25% signal @ 210 Bar (3045 PSi) &amp; 40°C (104°F)</b> 90° phase lag > 250 Hz -3dB attenuation > 250 Hz.
<b>Null Shift:</b>	With supply pressure: < 4% of full signal over the range of 124 Bar (1798 PSi) -228 Bar (3307 PSi). With fluid temperature < 5% of full signal over a range of 30-100 °C (86°F-212°F).	With supply pressure: < 4% of full signal over the range of 124 (1798 PSi) -228 Bar (3307 PSi). (Corresponding to 1.6% of full flow). With fluid temperature < 5% of full signal over a range of 30-100 °C. (86°F-212°F) (Corresponding to 2% of full flow).
<b>Accuracy of Flow Control:</b>	Hysteresis < 3%. Threshold < 0.5%.	Hysteresis < 3% of full signal (Corresponding to 1.2% of full flow). Threshold < 0.5% of full signal (Corresponding to 0.2% of full flow).
<b>Environmental Survivability Limits:</b>	165°C (329°F) & 25G shock load (Any axis).	
<b>Mass:</b>	92g (3.24 oz).	
<b>ENVIRONMENTAL OPERATING ENVELOPE FOR ALL E024 SERVOVALVES</b>		
<b>Pressure Supply:</b>	160 (2321 PSi) – 250 Bar (3626 PSi).	
<b>Return Line Pressure:</b>	2 (29 PSi) – 5 Bar (72 PSi).	
<b>Temperature Range:</b>	0 – 135 °C (0 - 275°F).	
<b>Fluids Viscosity:</b>	> 4 CSt.	
<b>Filtration:</b>	NAS 1638 Class 3 / ISO 4406 12/8 or better It may be possible to operate the valve in certain applications outside of these design limits, but this must be checked and validated by the customer.	
<b>Operation of Valves in Close Proximity:</b>	Valves mounted in close proximity may experience magnetic interaction. The degree of interaction depends on the installation and may be minimized by the use of external shielding.	

Moog has offices around the world. For further information, or the office nearest you, contact us online.

e-mail: [info@moog.com](mailto:info@moog.com).

[www.moog.com/industrial](http://www.moog.com/industrial)

Moog is a registered trademark of Moog Inc. and its subsidiaries. All trademarks as indicated herein are the property of Moog Inc. and its subsidiaries. © 2009 Moog Inc. All rights reserved. All changes are reserved.

This technical data is based on current available information and is subject to change at anytime by Moog. Specifications for specific systems or applications may vary.

**MOOG**